

CODE A: UL-PNC-009-A CODE B: UL-PNC-009-B

Benches

THE[®]
ITALIAN
LAB

CLUB seat

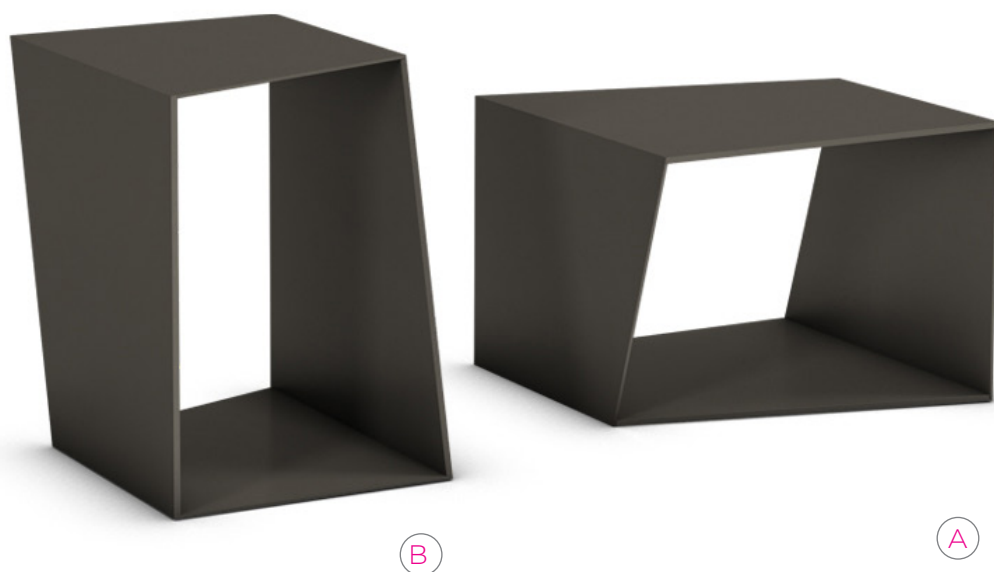

Dimensions and Weight:

A: L 610, W 750, H 450 mm, Weight 87.4 Kg

B: L 450, W 750, H 610 mm, Weight 87.3 Kg

The CLUB seat is made by the welding of 4 80/100 mm thick cold galvanized and polyester powder coated steel sheets.

Ground fixing is with 4 suitable M8 bolts (not supplied), or by placing the 10-mm rebar extensions 250 mm into concrete foundations.

A

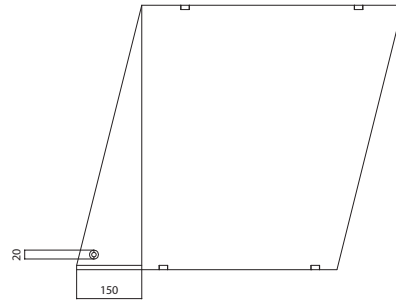
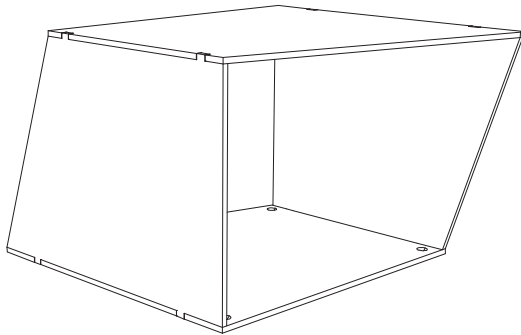
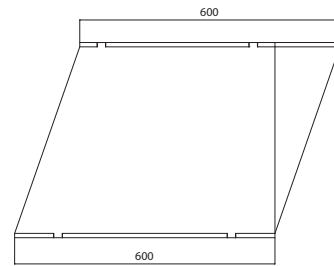
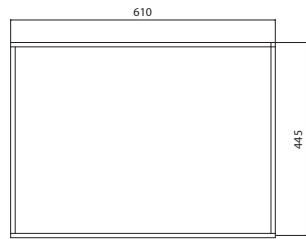

B

