

CODE: UL-PNC-070 CODE DA CEMENTARE: UL-PNC-070S

CODE: UL-PNC-071 CODE DA CEMENTARE: UL-PNC-071S

Panchine

Panchina ELES

5 THE[®]
ITALIAN
LAB



(A) (B)

Design: Ramos Bassols

(A) L 1950

UL-PNC-070

Dimensioni:

L 1950, P 645 H seduta 430, totale H 744 mm

Peso: 122 Kg

UL-PNC-070S

Dimensioni:

L 1950, P 645 H seduta 430, totale H 894 mm

Peso: 133,1 Kg

(B) L 2900

UL-PNC-071

Dimensioni:

L 2900, P 645 H seduta 430, totale H 744 mm

Peso: 166,3 Kg

UL-PNC-071S

Dimensioni:

L 2900, P 645 H seduta 430, totale H 894 mm

Peso: 177,4 Kg

La panchina ELES è realizzata in lamiera di acciaio sp. 60/10 successivamente zincata e verniciata a polveri PP. La superficie della seduta e dello schienale è caratterizzata da una particolare texture, denominata "ELES". Le zampe della panchina sono realizzate in

acciaio zincato sp. 10 mm successivamente verniciate a polveri PP, il basamento di dimensioni 150x460 mm è saldato alle zampe e presenta nr 4 fori Diam. 12 mm per il fissaggio al suolo con appositi tasselli (non forniti) sotto il livello del suolo.

A

CODE: UL-PNC-070

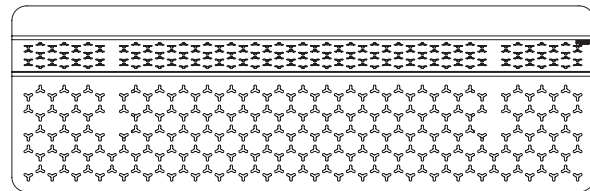
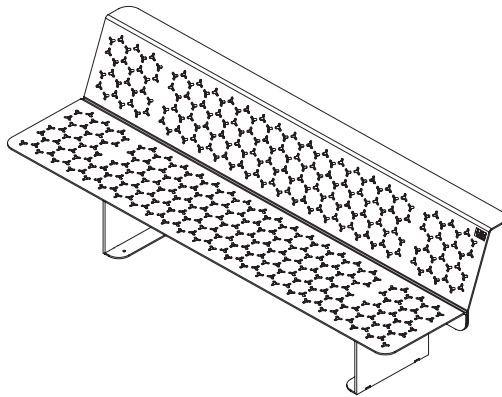
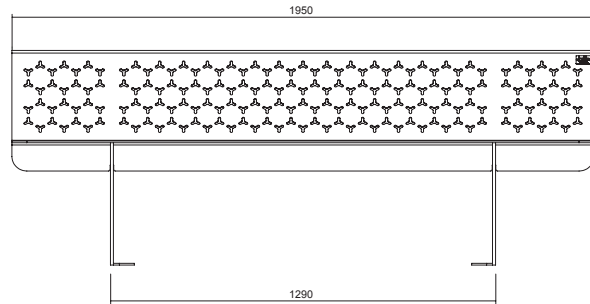
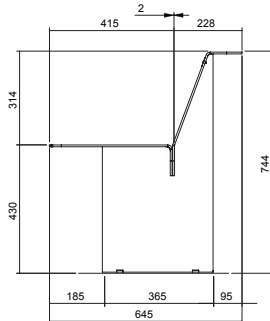

CODE DA CEMENTARE: UL-PNC-070S

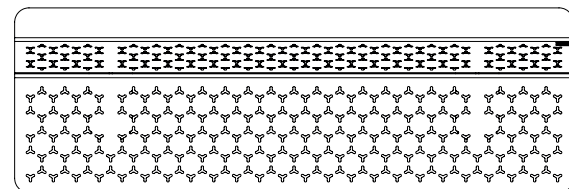
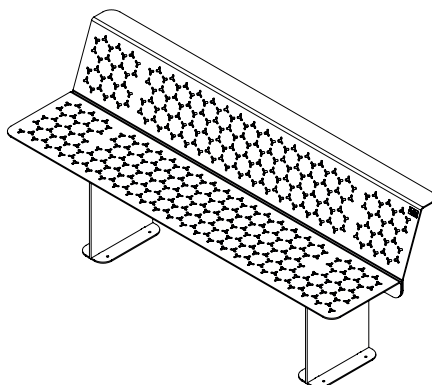
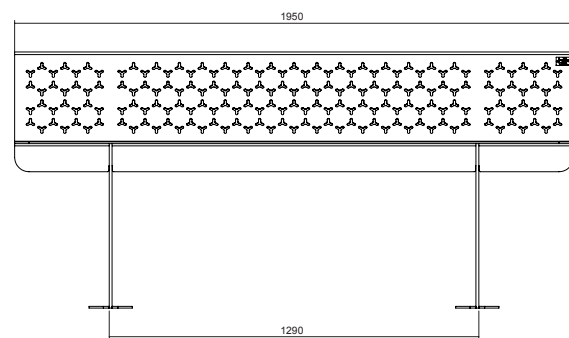
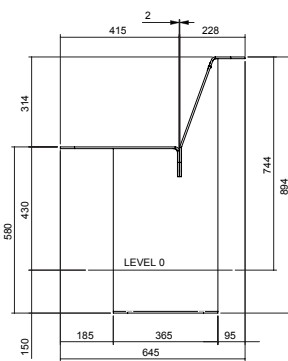

B

CODE: UL-PNC-071

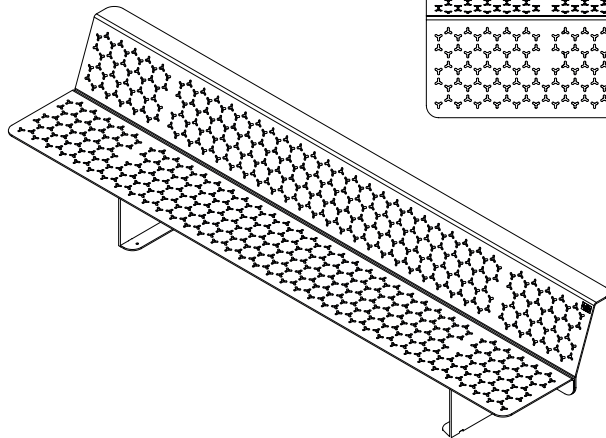
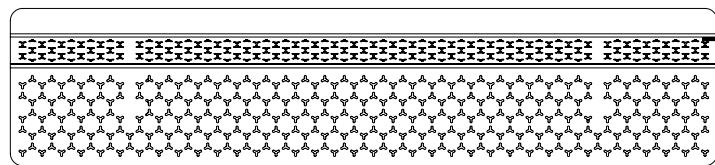
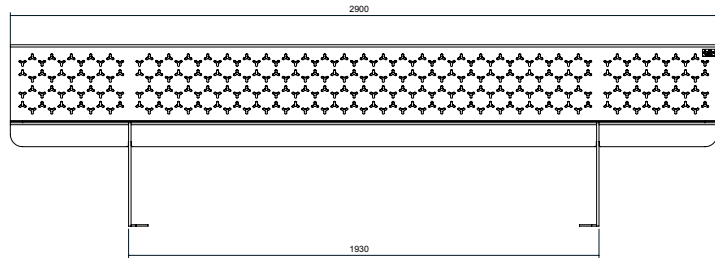
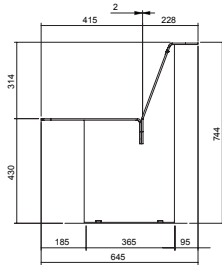

CODE DA CEMENTARE: UL-PNC-071S

