

CODE: UL-PNC-074 CODE TO BE CEMENTED: UL-PNC-074S

CODE: UL-PNC-075 CODE TO BE CEMENTED: UL-PNC-075S

# Benches

ELES seat

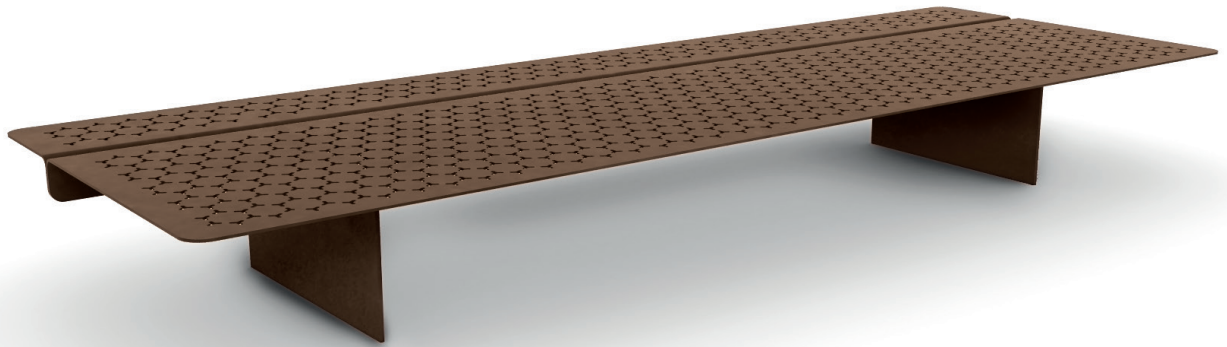

**5** THE<sup>®</sup>  
ITALIAN  
LAB

(A) (B)

Design: Ramos Bassols

(A) L 1950

UL-PNC-074

Dimensions: L 1950, W 1100 H seat 430

Weight: 158,9 Kg

UL-PNC-074S

Dimensions: L 1950, W 1100 H seat 430

Weight: 179,2 Kg

(B) L 2900

UL-PNC-075

Dimensions: L 2900, W 1100 H seat 430

Weight: 212 Kg

UL-PNC-075S

Dimensions: L 2900, W 1100 H seat 430

Weight: 232,3 Kg

The seat Eles is made of 60/10 thick galvanized and polyester powder coated steel; the seat is made by joining two bent sheets, one wider than the other, size 310x1950 / 2900 mm e 790x1950/2900 mm.

The surface of the seat is characterized by a particular texture, called "ELES".

The legs of the bench are made of 10 mm thick galvanized and polyester powder coated steel.

The base, size 150x660 mm, is welded to the legs, and is supplied with 4 holes of diameter 12 mm for ground fixing with appropriate bolts (not included).

A

CODE: UL-PNC-074

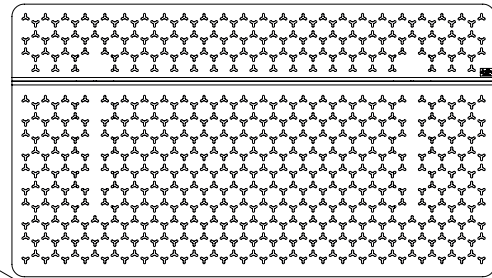
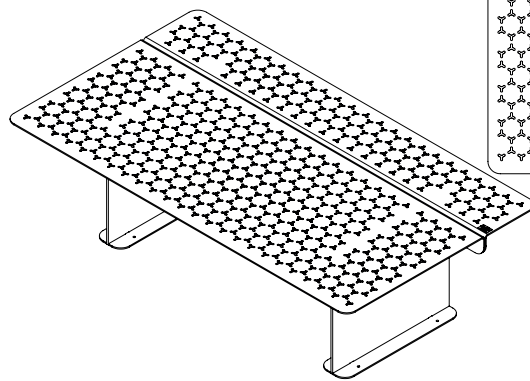
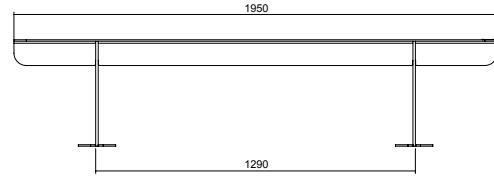
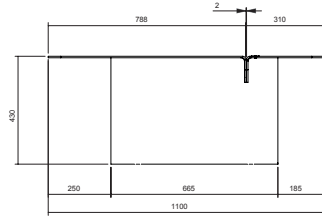

CODE TO BE CEMENTED:: UL-PNC-074S

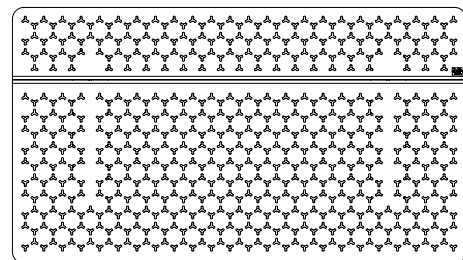
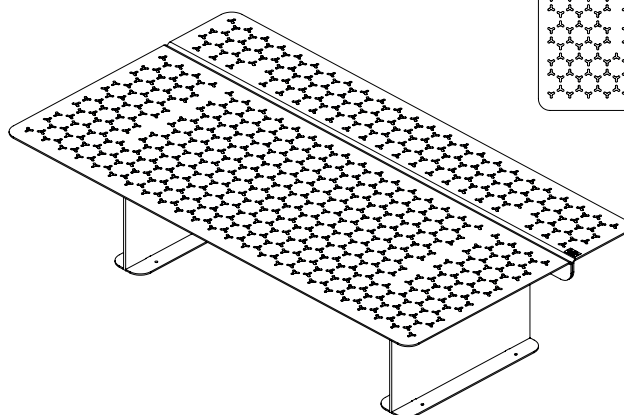
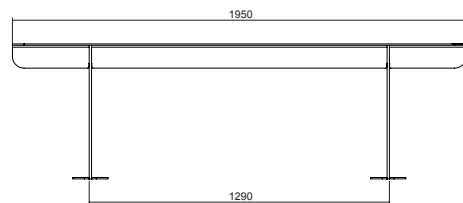
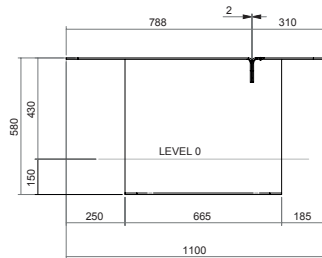

B

CODE: UL-PNC-075

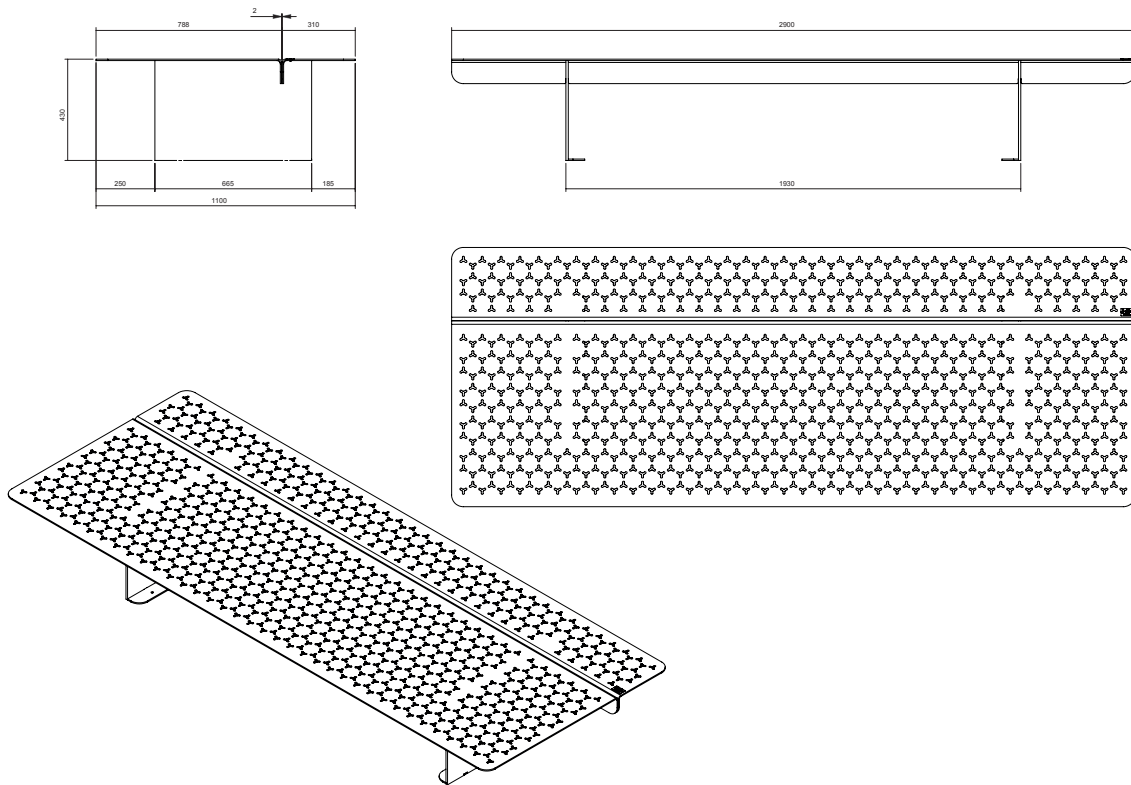

CODE TO BE CEMENTED:: UL-PNC-075S

