

CODE A: UL-PNC-046 CODE B: UL-PNC-047 CODE C: UL-PNC-048

Panchine

SECTION

S THE[®]
ITALIAN
LAB



Dimensioni:

- A) L 900, P 720, H 495 mm
- B) L 1500, P 720, H 495 mm
- C) L 2000, P 720, H 495 mm

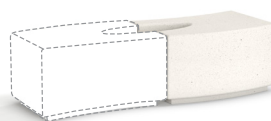

A

CODE: UL-PNC-046



OPTIONAL Luce led

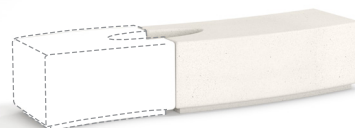

B

CODE: UL-PNC-047

La panca SECTION è realizzata con UHPC (ULTRA HIGH PERFORMANCE CONCRETE) e rinforzata con un'armatura interna in acciaio.

La panca è disponibile in tre varianti di diversa lunghezza per realizzare diverse composizioni e in varie colorazioni.



C

CODE: UL-PNC-048

A

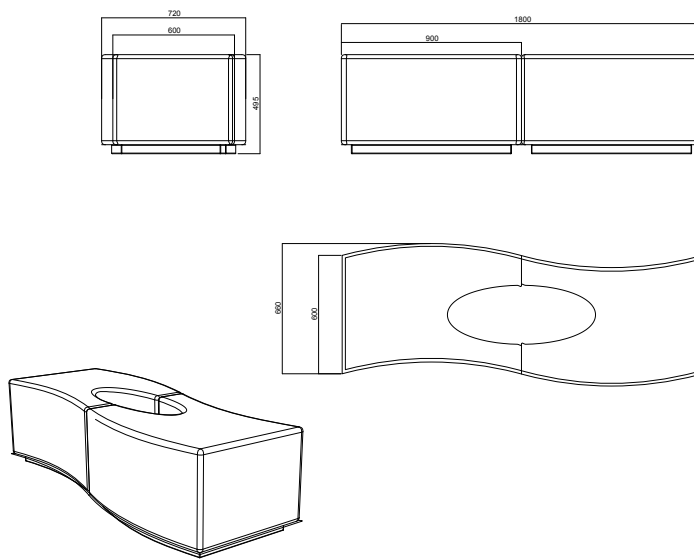

B

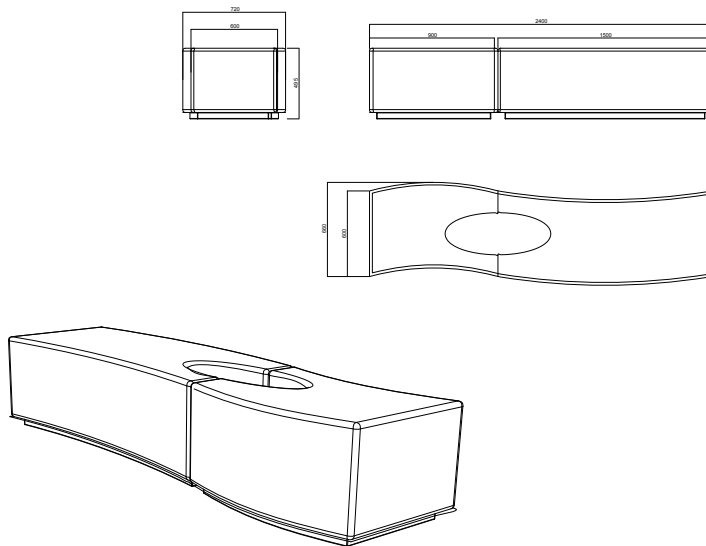

C

